

Overview

The BA/#-Ix-SS Double Threaded Stainless Steel (SS) Immersion Sensor is made for thermowell mounting and temperature measurement in water pipes, water tanks or cooling tower sump applications. Direct probe insertion into a Threadolet is possible without a thermowell. However, this is not recommended as it cannot be removed after the pipe is pressurized. The rigid probe and threads are made of Stainless Steel and made in different lengths for a custom thermowell fit. The BA/#-Ix-SS is available with multiple thermistor's or RTD's as shown in the specifications. Enclosure mounting styles come in plastic or metal for both NEMA 1 and NEMA 4 applications and are all plenum rated.

Identification

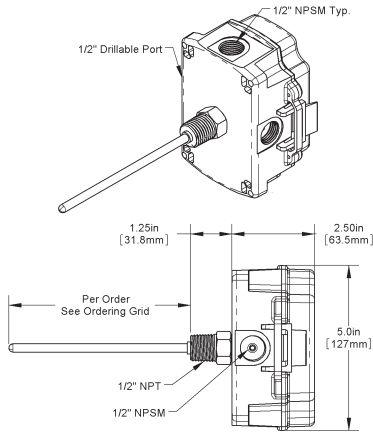

Fig 1: BAPI-Box (BB) Standard Mount

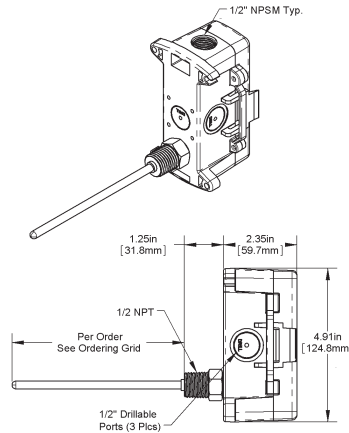

Fig 2: BAPI-Box 2 (BB2) Standard Mount

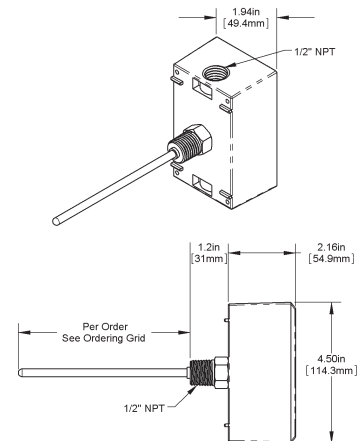

Fig 3: Weatherproof (WP) Standard Mount

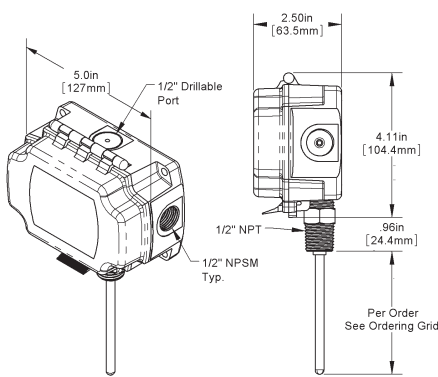

Fig 4: BAPI-Box (BB) Outside Mount

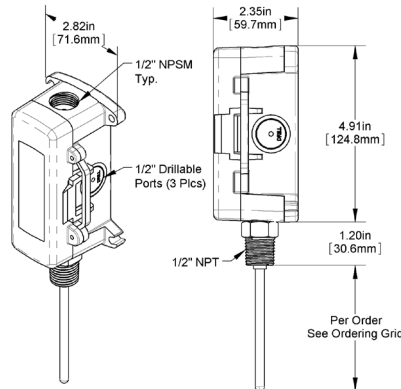

Fig 5: BAPI-Box 2 (BB2) Outside Mount

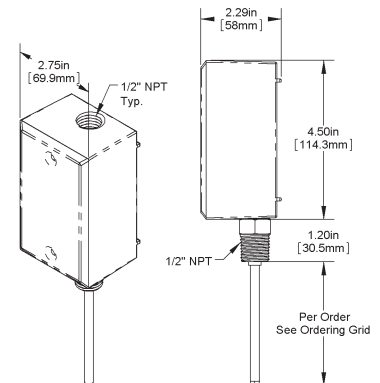

Fig 6: Weatherproof (WP) Outside Mount

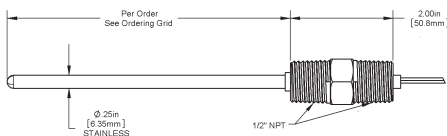

Fig 7: No Box (NB) Units

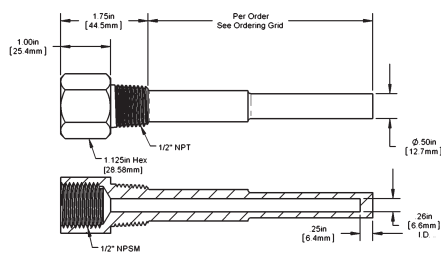

Fig 8: Machined Bar Stock Thermowell

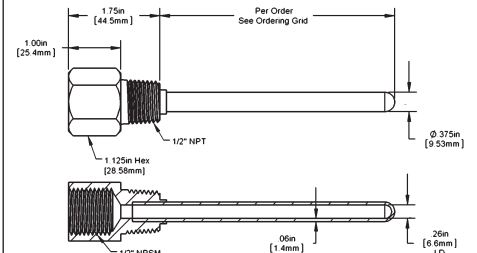

Fig 9: Two Part Welded Thermowell

Specifications subject to change without notice.

Mounting

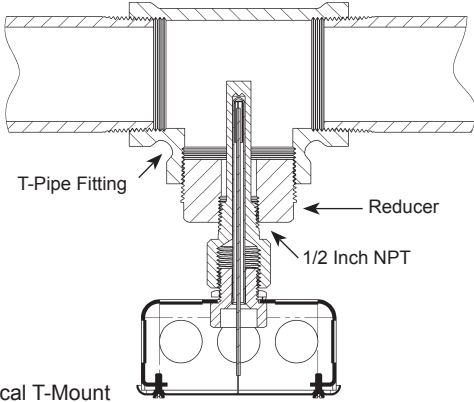

Fig 10: Typical T-Mount

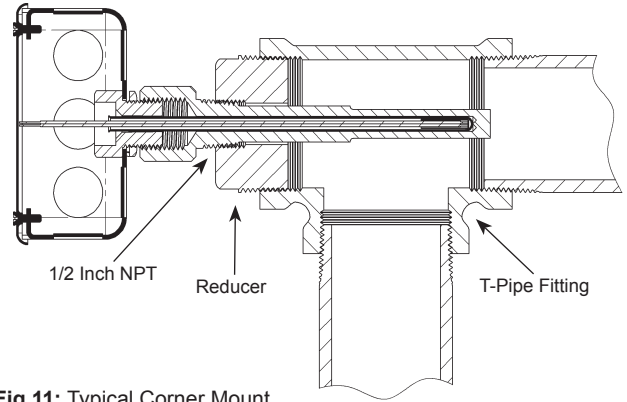

Fig 11: Typical Corner Mount

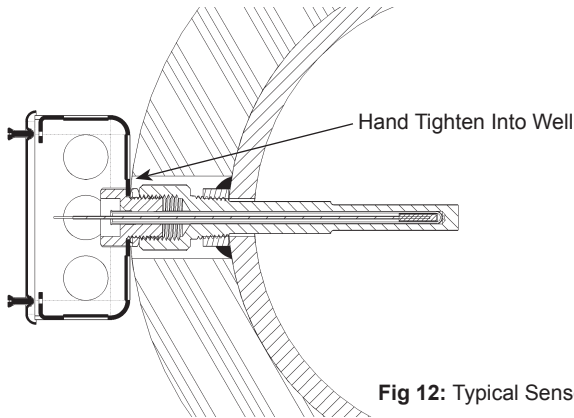

Fig 12: Typical Sensor Inserted

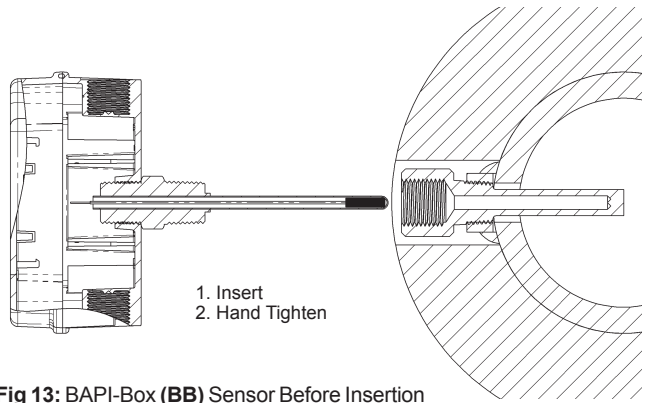

Fig 13: BAPI-Box (BB) Sensor Before Insertion

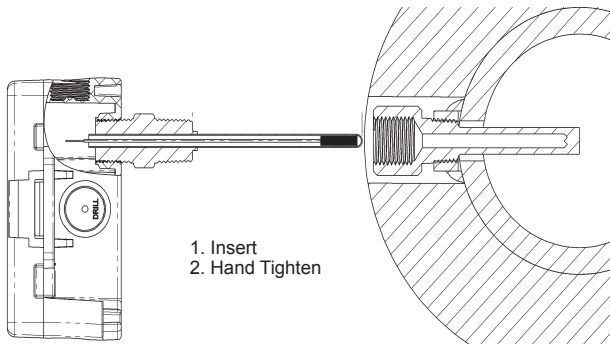

Fig 14: BAPI-Box 2 (BB2) Sensor Before Insertion

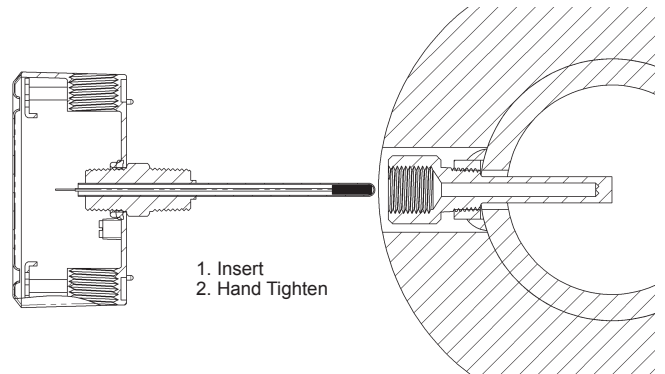

Fig 15: Weatherproof (WP) Sensor Before Insertion

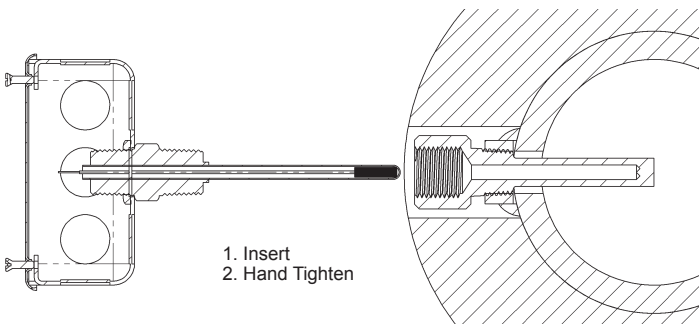

Fig 16: Standard J-Box Before Insertion

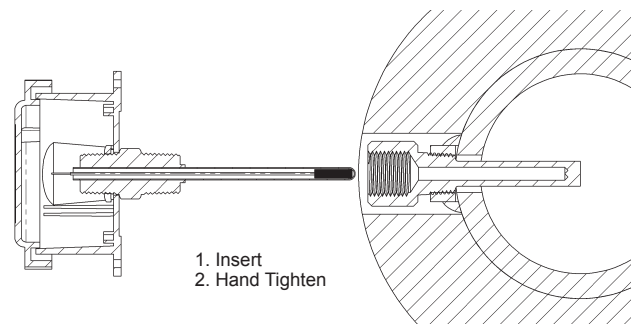

Fig 17: Weather Tight (EU) Sensor Before Insertion

Specifications subject to change without notice.

Application: Figure 12 shows a typical thermowell and immersion probe installed into a pipe. In a properly insulated pipe with liquid or steam, the temperature is essentially the same across the entire cross section of the pipe. Usually thermowells are sized to extend to the center of the pipe; however, shorter thermowells will give proper temperature readings if properly insulated. The shorter thermowells are used in pipes with high flow velocities. See Application notes “Thermowells Explained” on our website www.bapihvac.com.

Thermowell Installer: Typically a Pipe Fitter drills a 3/4-inch hole into the pipe where the thermowell is needed. A customer provided fitting, called a Threadolet or Weldolet, is welded to the pipe over the hole. The Threadolet has a 1/2” NPT thread in the center. Thread sealant such as Teflon tape or pipe dope is applied to the 1/2” NPT threads of the thermowell. The thermowell is then inserted into the Threadolet and tightened. Estimates on insertion depths can be seen in our Application note “Thermowells Explained” on our website www.bapihvac.com

Sensor Installation: Insert the immersion sensor into the well. Hand tighten the immersion sensor snugly without too much torque. The probe is tight fitting to the bottom and wall of the thermowell offering an accurate temperature reading. Direct probe insertion into the pipe without a thermowell is possible. However, this is not recommended as it cannot be removed after the pipe is pressurized. Apply a minimum of five turns of Teflon tap to the SS probe side threads. Insert the SS probe and 1/2” NPT threads into the Threadolet and tighten with a wrench to achieve a water tight seal. The probe should not touch the far inside of the water pipe or probe failure may occur.

Wiring & Termination

BAPI recommends using twisted pair of at least 22AWG and sealant filled connectors for all wire connections. Larger gauge wire may be required for long runs. All wiring must comply with the National Electric Code (NEC) and local codes. Do NOT run this device’s wiring in the same conduit as high or low voltage AC power wiring.

BAPI’s tests show that inaccurate signal levels are possible when AC power wiring is present in the same conduit as the sensor wires.

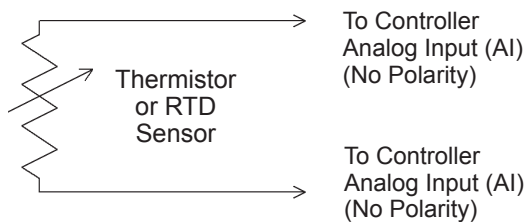

Fig. 18: 2 Wire Lead Wire Termination for Thermistor or RTD

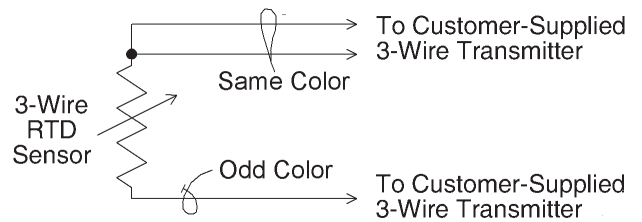

Fig. 19: 3 Wire Lead Wire Termination for RTD

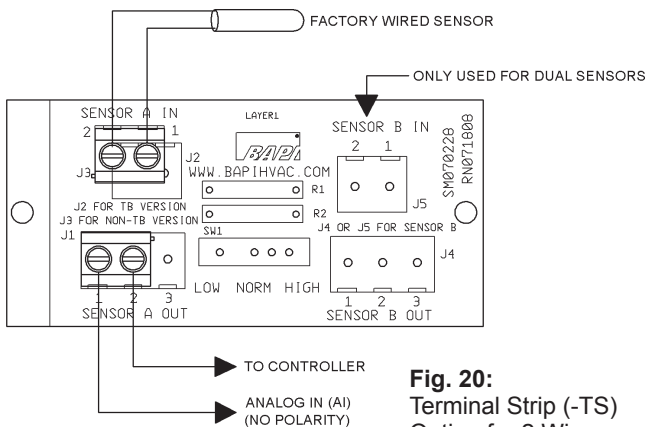

Fig. 20: Terminal Strip (-TS) Option for 2 Wire Sensors Termination

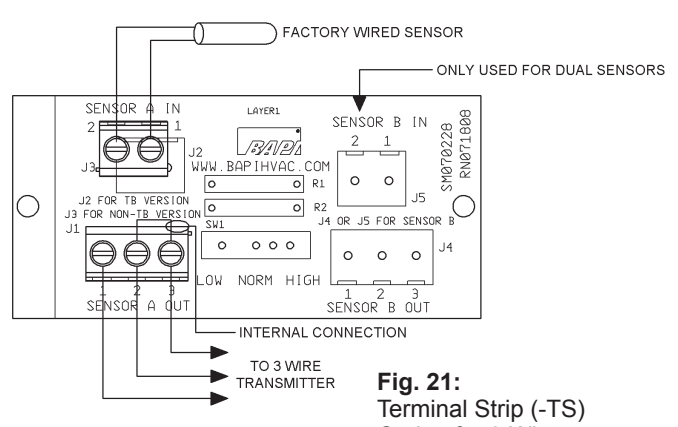

Fig. 21: Terminal Strip (-TS) Option for 3 Wire Sensors Termination

Specifications subject to change without notice.

Wiring & Termination continued...

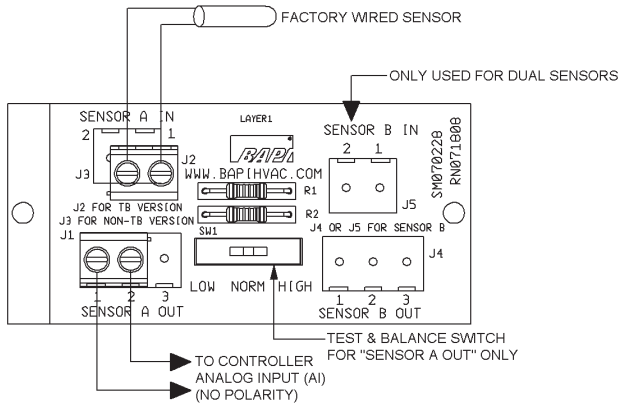

Fig. 22:
Test & Balance (-TB) Option
for 2 Wire Sensors Termination

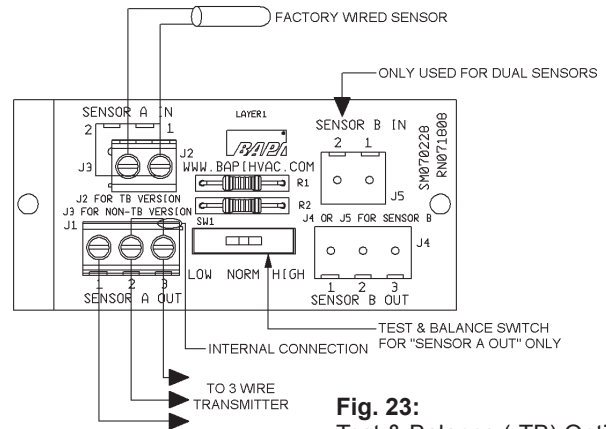

Fig. 23:
Test & Balance (-TB) Option
for 3 Wire Sensors Termination

Diagnostics

Problems:

Controller reports higher or lower than actual temperature

Possible Solutions:

- Confirm the input is set up correctly in the front end software
- Check wiring for proper termination & continuity. (shorted or open)
- Disconnect wires and measure sensor resistance and verify the "Sensor" output is correct.

Specifications

Sensor	Passive	Lead Wire	22awg stranded
Thermistor	NTC, 2 wire	Wire Insulation	Etched Teflon, Plenum rated
RTD	PTC, 2 or 3 wire	Probe	Rigid, 316 Stainless Steel, 0.25" OD
Thermistor	Thermal resistor	Probe Length	2", 4", 8" or custom per order
Temp. Output	Resistance	Mounting	1/2" NPT, 316 Stainless Steel Double Threaded Fitting
Accuracy (Std)	±0.36°F, (±0.2°C)	Enclosure Types	
Accuracy (Hi)	±0.18°F, (±0.1°C), [XP] option	Weatherproof	-WP, w/ two 1/2" FNPT entries, (Bell box)
Stability	< 0.036°F/Year, (<0.02°C/Year)	BAPI-Box	-BB, w/four 1/2" NPSM & one 1/2" Drill-outs
Heat dissipation	2.7 mW/°C	BAPI-Box 2	-BB2, w/three 1/2" NPSM & three 1/2" Drill-outs
Temp. Drift	<0.02°C per year	Enclosure Ratings	
Probe range	-40° to 221°F (-40° to 105°C)	No Box	-NB, No Rating (Probe Only)
RTD	Resistance Temperature Device	Weatherproof	-WP, NEMA 3R, IP14
Platinum (Pt)	100Ω or 1KΩ@0°C, 385 curve,	BAPI-Box	-BB, NEMA 4, IP66
Platinum (Pt)	1KΩ@0°C, 375 curve	BAPI-Box 2	-BB2, NEMA 4, IP66
Pt Accuracy (Std)	0.12% @Ref, or ±0.55°F, (±0.3°C)	Enclosure Materials	
Pt Accuracy (Hi)	0.06% @Ref, or ±0.277°F, (±0.15°C), [A]option	Weatherproof	-WP, Cast Aluminum, UV rated
Pt Stability	±0.25°F, (±0.14°C)	BAPI-Box	-BB, Polycarbonate, UL94V-0, UV rated
Pt Self Heating	0.4 °C/mW @0°C	BAPI-Box 2	-BB2, Polycarbonate, UL94V-0, UV rated
Pt Probe range	-40° to 221°F, (-40 to 105°C)	Ambient (Encl.)	
Nickel (Ni)	1000Ω@70°F, JCI curve	Weatherproof	0 to 100% RH, Non-condensing
Ni Probe range	-40° to 221°F (-40 to 105°C)	BAPI-Box	-WP, -40°F to 212°F, (-40° to 100°C)
Sensitivity	Approximate @ 32°F (0°C)	BAPI-Box 2	-BB, -40°F to 185°F, (-40° to 85°C)
Thermistor	Non-linier	Agency	RoHS, *CE
RTD (Pt)	Go to bapihvac.com "Sensor Specs"		PT= DIN43760, IEC Pub 751-1983, JIS C1604-1989
3.85Ω/°C for 1KΩ RTD			*Passive Thermistors 20KΩ and smaller are CE Compliant
0.385Ω/°C for 100Ω RTD			
Nickel (Ni)	2.95Ω/°F for the JCI RTD		

Specifications subject to change without notice.